

HUILIDE 汇利得



苏州汇利得机械有限公司

地址：苏州市相城区北桥街道北灵路555号 邮编：215144

电话：+86-0512-80813856 传真：+86-0512 80813855

手机：+86-150 0613 9272 邮箱：david.su@hldmachine.com

邮编：215144 网址：www.hldmachine.com

David Su

Suzhou Huilide Machine Co.,Ltd.

Add: No.555,Beiling Rd.,Beiqiao Suzhou, Jiangsu, China,215144

Tel: +86-0512-80813856 Fax: +86-512 80813855

Mobile : +86-150 0613 9272

E-mail: david.su@hldmachine.com

Web:www.hldmachine.com

型号 Drum feeder model	DF 200	DF350	DF80
直径 Drum diameter(D)	200	350	800
长度 Drum length(L)	60-200	100-350	500-800
无碳刷直流电机，速度可调；结构紧凑，电机和滚筒平行 Brushless DC motor; speed can be adjusted to specific needs Compact bearings integrated into the drum housing, motor parallel to drum			

3. 离心式给料机

Centrifugal Feeder

在排序比较简单的情况下，为得到比较高的速度。为此，我们研发出了旋转给料机。旋转给料机允许以高速给料，速度可超过1000pcs/min，而且噪音低、振动小。

Sometimes it's simply not enough to feed and orient parts. Sometimes what you really need is high-speed orientation. Our centrifugal feeders are noted for their ability to feed and orient parts at high rates that cannot be matched by other types of parts feeders. In addition, the feeder performs at very low noise levels, improving the work environment for the operator.

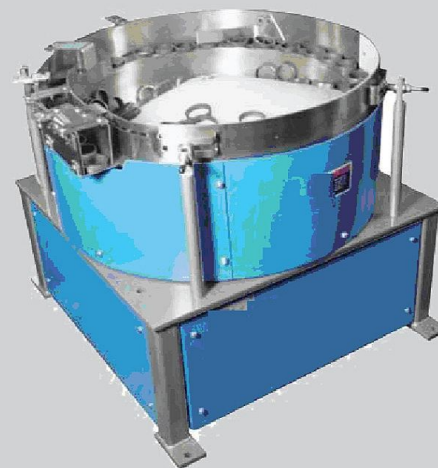

型号 model	尺寸 dimension(mm)			
	A	B	C	φ D
CF50	600	380 ± 10	345 ± 10	406
CF100	1100	535 ± 10	500 ± 15	812

